

Product Name	Dimensions	Number	Statement
L3224	Width: 225 mm	1	Connection Hole
	Height: 225 mm	2	Lighting Zone
	Length: 25 mm	3	Camera Field of View
		4	Product Cable



1.FEATURES

- Lighting Color: 6000K, Green, Red
- Lighting Angle: 30°, 60°
- Lighting Intensity: 1.92 k lm
- Number of Leds: 768
- Input Voltage: 24 V
- Input Current (15 μ s): 3.84 Amp
- Input Current (1 second): 2.4 Amp
- Input Current (1 minute): 1.92 Amp
- Input Current (continuous): 1.152 Amp
- Dimensions: 22.5 cm x 22.5 cm x 2,5 cm
- Constant Voltage Usage: Yes
- Diffuser Option: Yes

3.APPLICATIONS

- Engine Part Inspections
- Packaging Inspections
- Medical Bottle Inspections
- Food Package Inspections
- Surface Inspections
- Microscopic Camera Applications
- Particle Imaging in Liquid
- Particle Size Measurement
- Particle Counting
- Machine Vision
- Cell Identification
- Flame Length Measurement
- Edge Detection
- Material Strain Measurement (elongation / shortening / degradation)
- Motion Detection
- Product Counting
- Color Concentration Information
- Coordinate Information

2.DESCRPTIONS

- Backlighting is a crucial and widely employed technique in image processing projects, offering various advantages across different applications.

- Particle Identification
- Cell Imaging
- Machine Monitoring
- Image Processing
- Industrial Led Lighting
- Conveyor Line Lighting
- Robot Vision Applications
- Industry 4.0 Applications
- Machine Lighting
- Bar Light
- Dark Field Light
- Panel Lighting
- Dark Effect Lighting
- Dome Light
- Ring Light
- Panel Light
- Back Light
- Dome Type
- Lighting





4.LIGHT CHARACTERISTICS

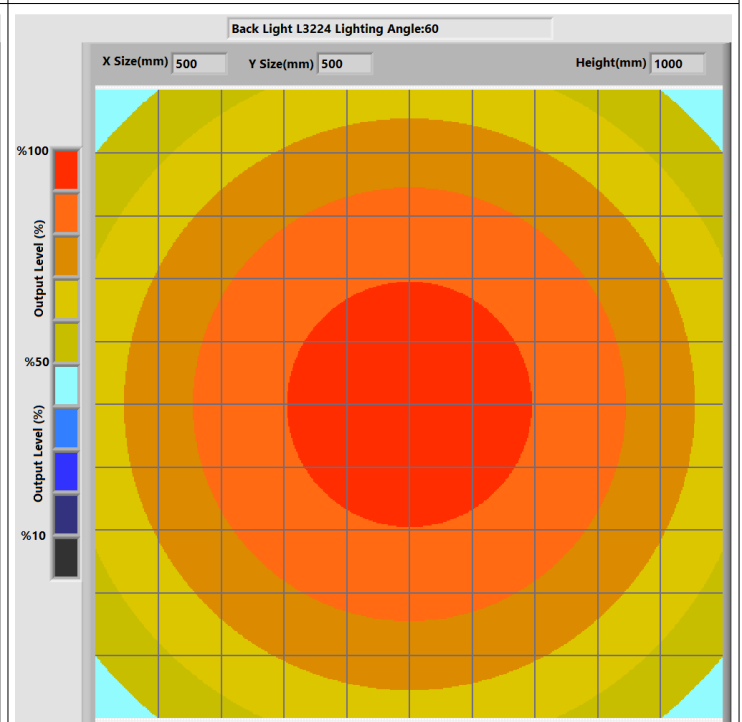
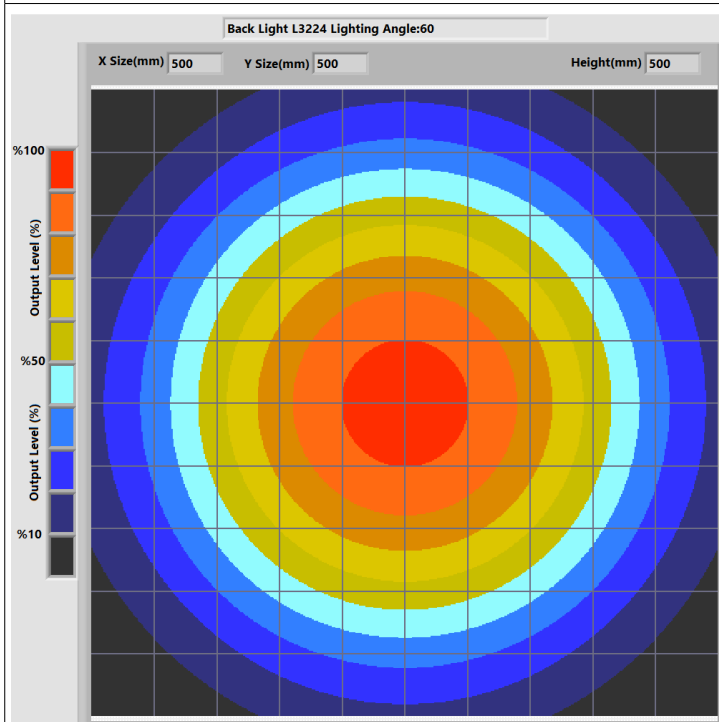
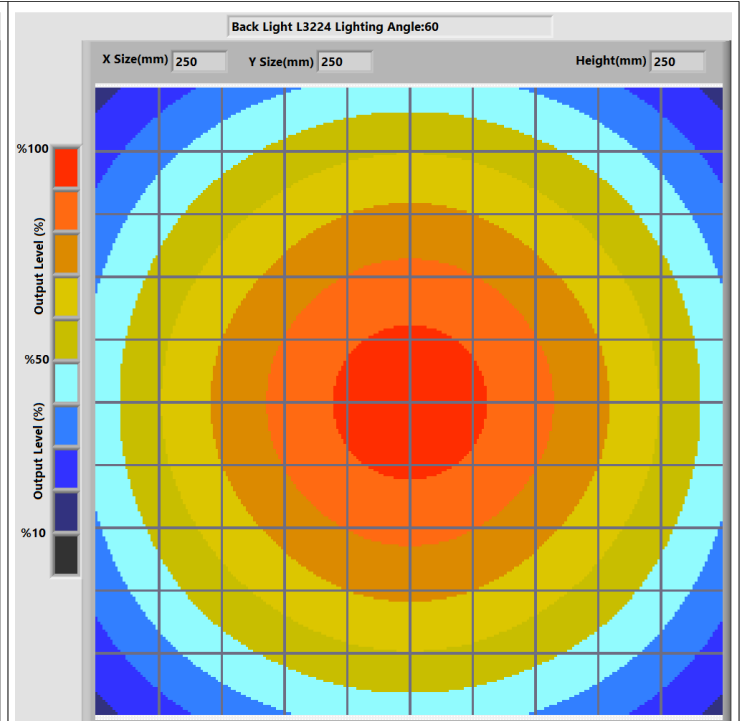
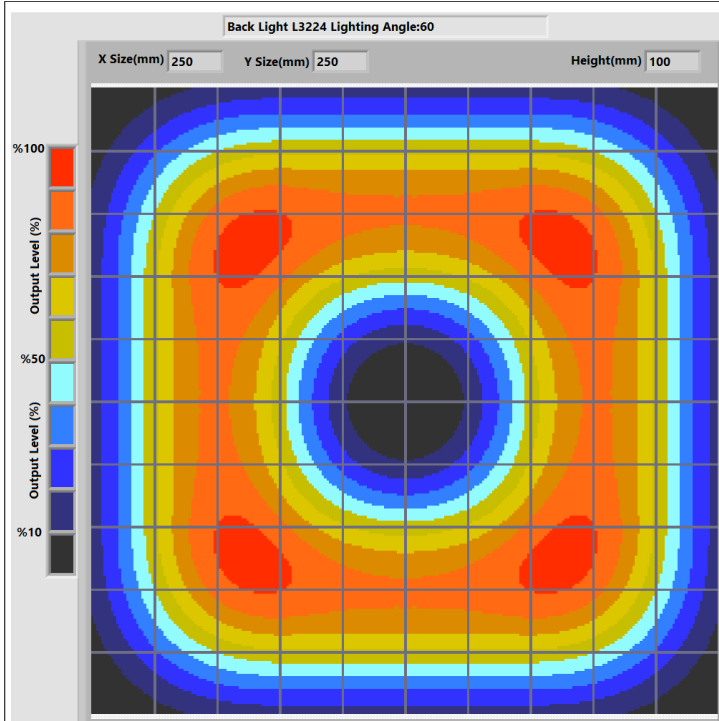



Prion Industrial Lighting

Back Light

L3224

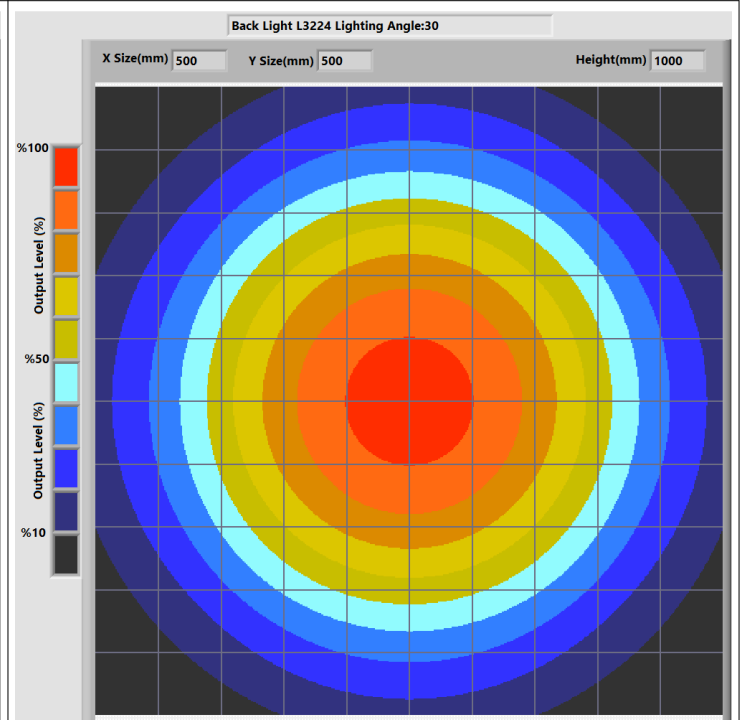
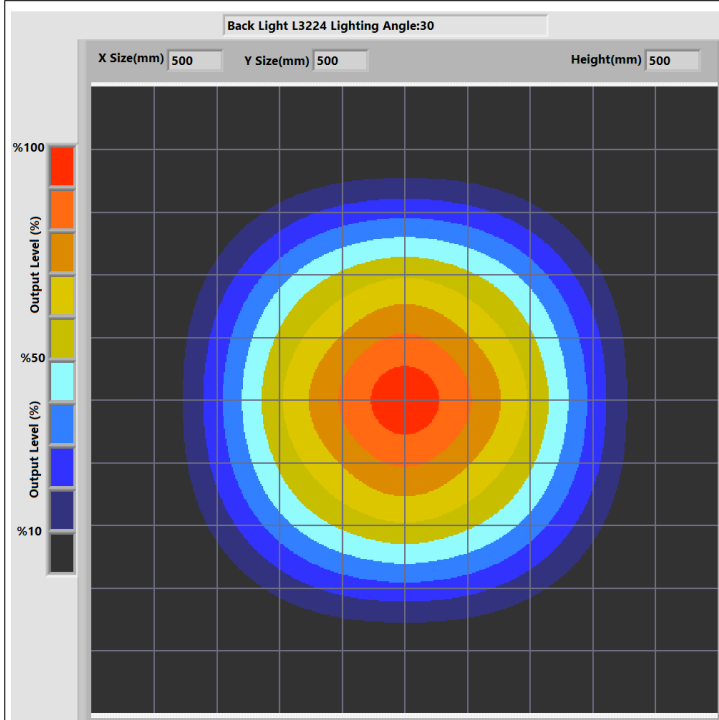
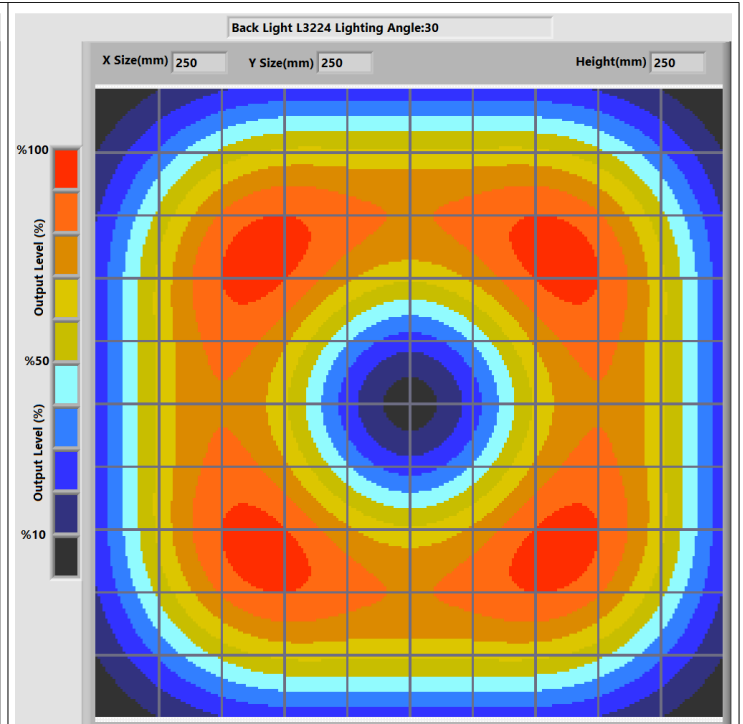
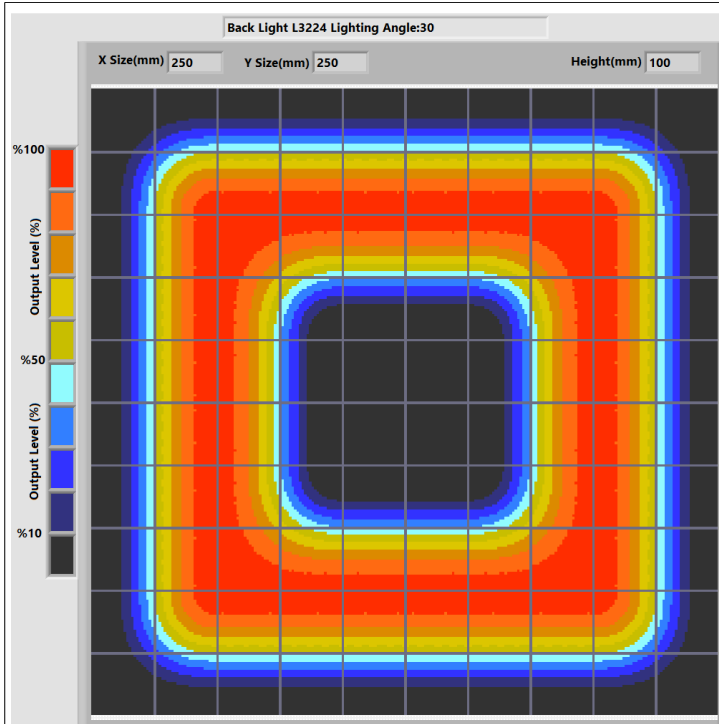

Pelin Street, Nuhoğlu Stage 2
Kadıköy/İstanbul/Turkey





E-Mail: info@ludre.com.tr
Contact: +90 216 519 08 54



Prion Industrial Lighting

Back Light

L3224

<p>Lens:12mm</p> <p>Money</p>  <p>Camera h:170mm</p> <p>Light h:160mm</p>	<p>Lens:12mm</p> <p>Cap</p>  <p>Camera h:170mm</p> <p>Light h:160mm</p>
<p>Lens:12mm</p> <p>Nut</p>  <p>Camera h:170mm</p> <p>Light h:160mm</p>	<p>Lens:12mm</p> <p>Bolt</p>  <p>Camera h:170mm</p> <p>Light h:160mm</p>





Prion Industrial Lighting

Back Light

L3224

Lens:12mm

Terminal

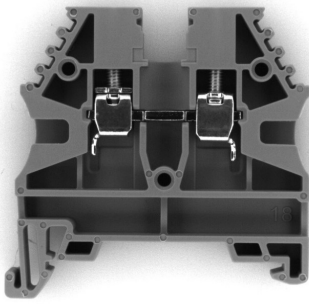

Camera h:170mm

Light h:160mm

Lens:12mm

Can



Camera h:230mm

Light h:160mm

Lens:12mm

Cap



Camera h:230mm

Light h:160mm

Lens:12mm

Toy

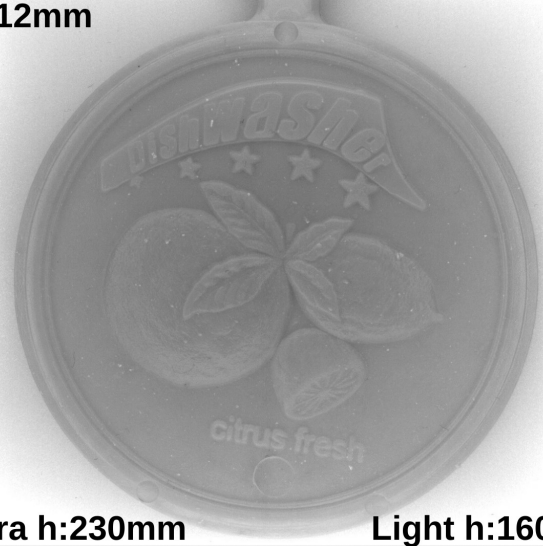

Camera h:230mm

Light h:160mm



Pelin Street, Nuhoglu Stage 2
Kadiköy/İstanbul/Turkey

E-Mail: info@ludre.com.tr
Contact: +90 216 519 08 54



Prion Industrial Lighting

Back Light

L3224

Lens:12mm

Box

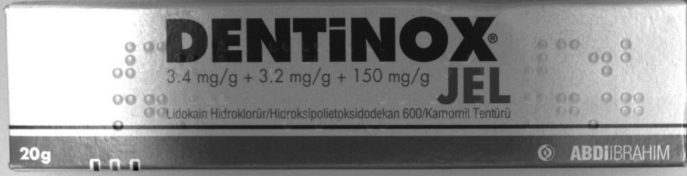

Camera h:230mm

Light h:160mm

Lens:12mm

Package



Camera h:230mm

Light h:160mm

Lens:12mm

Pcb

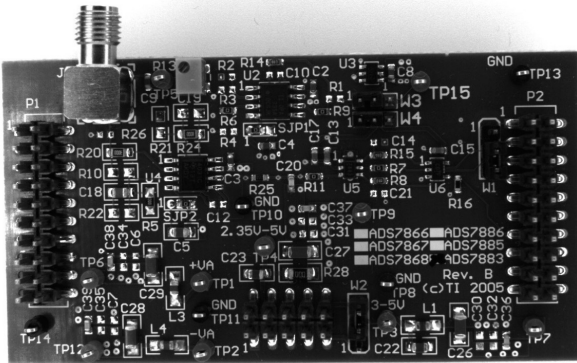

Camera h:230mm

Light h:160mm

Lens:12mm

Package



Camera h:230mm

Light h:160mm



Pelin Street, Nuhoğlu Stage 2
Kadıköy/İstanbul/Turkey

E-Mail: info@ludre.com.tr
Contact: +90 216 519 08 54

5.PRODUCT USE

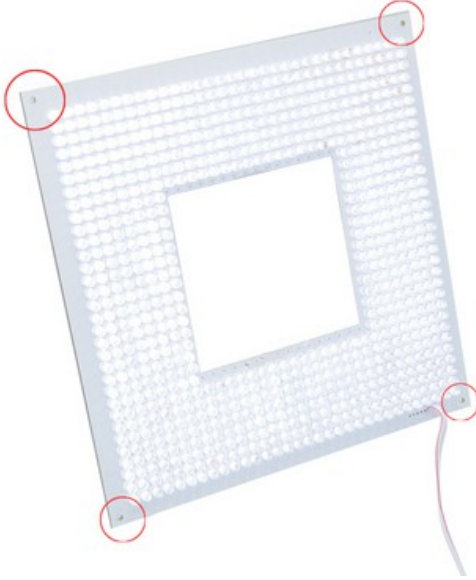

Mounting to the machines is possible with the bolt and nut assembly in the areas indicated in the adjacent image.

The points to be taken into consideration during this installation are as follows: The electronic parts should not be contacted while assembling the product.

In addition, if the product is not installed properly, vibrations that may occur will cause errors during measurement and control.

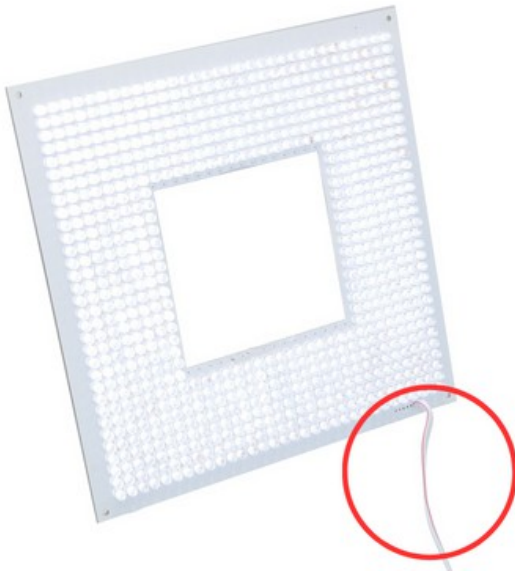

The product is powered by a 2M long cable fixed on it.

We need to make the 24V DC+ connection from our cable line with a red stripe, and we need to make the GND connection from our single color cable line.

When the supplies are connected in reverse, the product will not be damaged, but the product will not work. Cuts, breaks, etc. on the cable. If there is a problem, please contact us before using the product.



6.DIMENSIONS

L3224

